



Description

The ZCC2007 is a high efficiency, high power density, current mode, fully integrated boost converter with output disconnect, which can start up from an input voltage as low as 1.8V and convert up to 5.5V output voltage. During shutdown, it can disconnect the output from input.

This converter integrates two 13A/20mΩ power switches for high converter efficiency and can deliver up to 3A output current at 5V output with 2.5V input supply. When the output is shorted, the ZCC2007 enters hiccup protection mode and recover automatically when the output short is removed.

The ZCC2007 also includes input under-voltage lockout, output over-voltage protection, cycle-by-cycle over-current protection, short circuit protection and thermal shutdown to prevent damage in the event of output overload. The ZCC2007 is available in a low profile 10-pin 2mmx2mm FCQFN package.

Features

- Input Voltage Range: 1.8V to 5.5V
- Output Voltage Range: 2.5V to 5.5V
- 13-A Peak Switching Current Limit
- Two 20-mΩ(LS)/20-mΩ(HS) MOSFETs
- 30uA Quiescent Current
- Internal Compensation and Soft-start
- True Load Disconnect from Input
- Low Shutdown Current < 1μA
- Output Overvoltage Protection
- OVP, OCP, SCP and OTP Protection
- High Efficiency over Whole Load Range
- Small 2x2mm QFN 10-Pin Package

Applications

- Tablets
- USB Power Supply
- Battery Powered Products
- Power Bankers, Battery Back-up Units

Typical Application

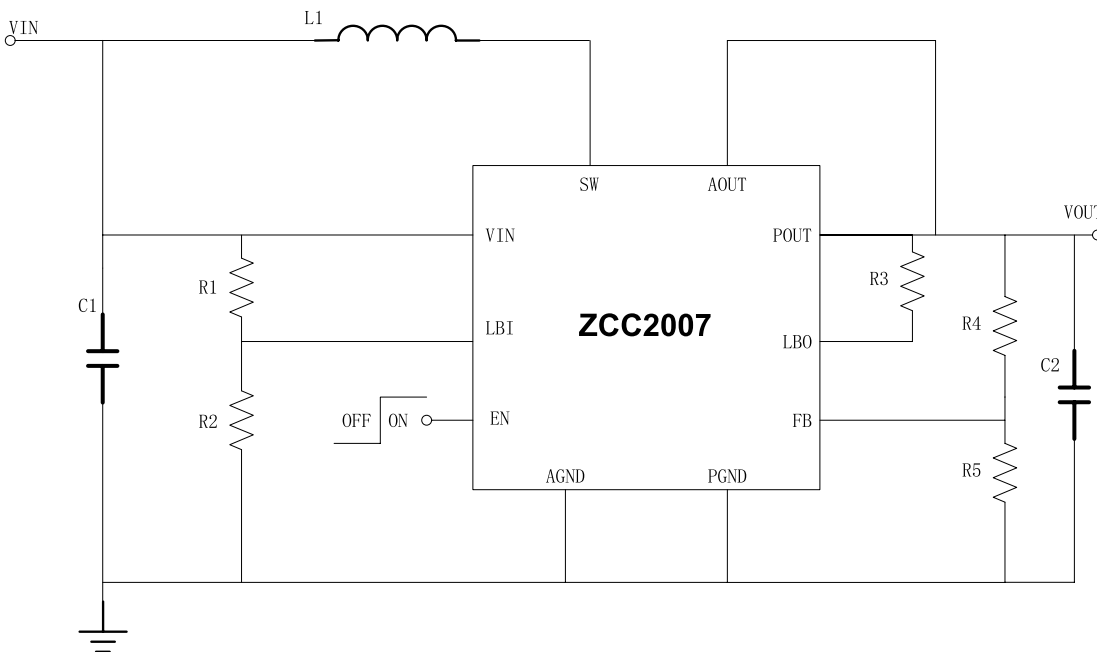



无锡市至诚微电子有限公司
ZCC2007
5V/7A High Efficiency Synchronous Boost Converter

Ordering Information

Part Number*	Package	Top Marking
ZCC2007	FCQFN-10 (2x2mm)	ZCC2007 XXXXX

Package Reference

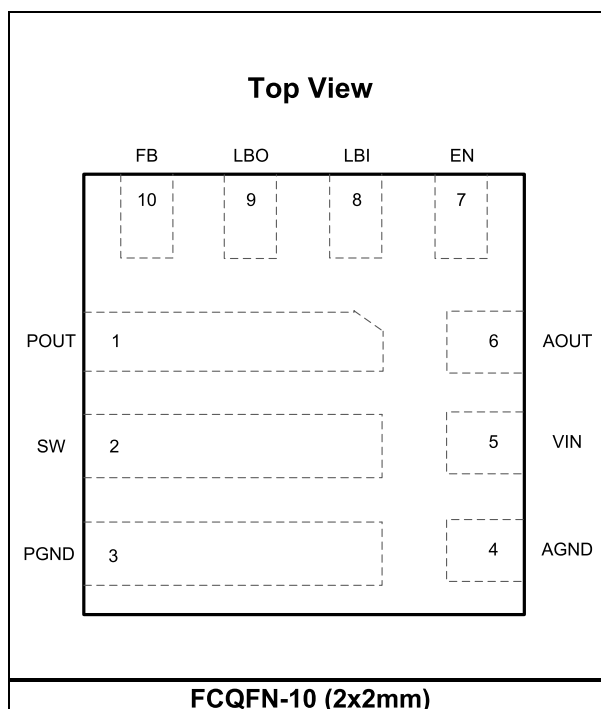

Pin Functions

Package Pin #	Name	Description
1	POUT	Power output.
2	SW	Power Switch Output. SW is connected to the internal main switch and synchronous switch.
3	PGND	Power ground.
4	AGND	Analog ground.
5	VIN	Input supply. VIN must be locally bypassed.
6	AOUT	Analog output.
7	EN	Enable pin of the chip. This pin is internally integrated with a 1Mohm pull-down resistor.
8	LBI	Low battery comparator input (comparator enabled with EN).
9	LBO	Low battery comparator output (open drain).
10	FB	Feedback Input. Connecting a resistor divider from VOUT to this pin to adjust VOUT voltage. This pin must be connected to VOUT on fixed VOUT voltage version.





Absolute Maximum Ratings ⁽¹⁾

SW.....	-0.3V to +6V (9V for < 5ns)
All Other Pins.....	-0.3V to +6 V
Junction Temperature.....	150°C
Lead Temperature.....	260°C
Storage Temp.....	-65°C to +150°C
Continuous Power Dissipation (TA= +25°C) ⁽²⁾	
2mmx2mm FCQFN-10.....	2.5W

Recommended Operating Conditions ⁽³⁾

Supply Voltage V_{IN}	1.8V to 5.5V
Output Voltage V_{OUT}	2.5V to 5.5V
Operating Junction Temp.	-40°C to +125°C

Thermal Resistance ⁽⁴⁾	θ_{JA}	θ_{JC}	
FCQFN-10 (2x2mm)	50	10	°C/W

Notes:

- 1) Exceeding these ratings may damage the device.
- 2) The maximum allowable power dissipation is a function of the maximum junction temperature T_J (MAX), the junction-to-ambient thermal resistance θ_{JA} , and the ambient temperature T_A . The maximum allowable continuous power dissipation at any ambient temperature is calculated by P_D (MAX) = $(T_J$ (MAX)- T_A)/ θ_{JA} . Exceeding the maximum allowable power dissipation will cause excessive die temperature, and the regulator will go into thermal shutdown. Internal thermal shutdown circuitry protects the device from permanent damage.
- 3) The device is not guaranteed to function outside of its operating conditions.
- 4) Measured on 4-layer PCB at T_A = +25°C.

Electrical Characteristics

$V_{IN} = V_{EN} = 3.3V$, $V_{OUT} = 5V$, $T_A = +25^\circ C$, unless otherwise noted.

Parameter	Symbol	Condition	Min	Typ	Max	Units
Operating Input Voltage	V_{IN}		1.8		5.5	V
Undervoltage Rising	V_{INUVLO_R}	V_{IN} Rising			1.8	V
Undervoltage Falling	V_{INUVLO_F}	V_{IN} Falling		650		mV
Supply Current (Shutdown)	I_{INS}	$V_{EN} = 0V$, Measured at V_{IN}		0.1	1	μA
Supply Current (Quiescent)	I_{INQ}	IC enabled, No load , No Switching, Measured at V_{IN}		0.3	1	μA
	I_{OUTQ}	IC enabled, No load , No Switching, Measured at V_{OUT}		30		μA
Switching Frequency	F_S			500		kHz
Maximum Duty Cycle	D_{MAX}			95		%
EN High Threshold	V_{ENH}	V_{EN} Rising			1.0	V
EN Low Threshold	V_{ENL}	V_{EN} Falling	0.4			V
Feedback Voltage	V_{FB}		788	800	812	mV
High-side MOSFET On-resistance	R_{ONH}			20		m Ω
Low-side MOSFET On-resistance	R_{ONL}			20		m Ω
Linear Charge Current Limit ⁽⁵⁾	I_{LIM_LN}	$V_{OUT} = 0V$		0.2		A
		$V_{OUT} = 1.5V$		2		
SW Current Limit ⁽⁵⁾	I_{LIM_SW}		13			A
Output Overvoltage Protection Threshold	V_{OVP}			5.7		V
LBI Threshold	V_{LBI}	V_{LBI} falling	490	500	510	mV
LBI Hysteresis	V_{LBIhys}			10		mV
Soft-start Time	T_{SS}			2		ms
Thermal Shutdown	T_{SD}			150		°C
Thermal Shutdown Hysteresis	T_{SDhys}			25		°C





OPERATION

The ZCC2007 is a high efficiency synchronous boost converter with true output disconnect. The device features fixed frequency (600kHz) current-mode PWM control for excellent line and load regulation. Integrated low on-resistance power switches, combining with frequency stretching and power save mode (PSM) at light loads, improve the efficiency over a wide load range. Internal soft-start and loop compensation simplifies the design process and minimizes the number of external components.

Enable and Disable

The device is enabled by setting EN pin high (>1.2V). When EN pin is pulled to ground, the device is disabled, switching is stopped and all internal circuitry is turned off. The output is isolated from the input.

Start-up

After the device is enabled, the internal reference and bias circuits are activated when the rising VIN trips the under-voltage lockout threshold (V_{INUVLO_R}). At first, the PMOS rectifier turns on to charge the output capacitor linearly in linear charge mode. The device exits linear charge mode when the output is charged to 1.7V. In linear charge mode, the PMOS charging current is being regulated to avoid inrush current and limit the output current during short-circuit protection (SCP). This charging current is proportional to the output voltage, which is 0.2A when the output is 0V and ramps to 0.7A when the output is 1.7V. Once the output reaches 1.7V, the device starts switching and the output slowly ramps up to the targeted value in soft-start.

Soft Start (SS)

In linear charge mode, the soft-start voltage follows the voltage on FB pin. As the device starts switching, the soft-start voltage is rising slowly by charging an internal capacitor with a current source. The reference voltage rises at the same rate of soft-start voltage. The soft-start ends when the soft-start voltage reaches

0.8V. The typical soft-start time is 2ms. Soft-start mechanism prevents high inrush current from the input power supply.

PWM and PSM

The ZCC2007 automatically enters power save mode (PSM) when the load decreases and resumes pulse width modulation (PWM) mode when the load increases. In the PWM mode, at the beginning of each cycle, the internal N-channel MOSFET switch is turned on, forcing the inductor current to rise. The current of this switch is internally measured and converted to a voltage by the current sense amplifier. That voltage is compared to the output voltage of the error amplifier. When these two voltages are equal, the PWM comparator turns off the internal N-channel MOSFET switch and forces the inductor current flowing into the output capacitor through the internal P-channel MOSFET switch. This causes the inductor current to decrease. The peak inductor current is controlled by V_{COMP} , which in turn is controlled by the output voltage. Thus the output voltage is regulated through the inductor current to satisfy the load. In the PSM, the device lowers the switching frequency and then switches to pulse skip mode if the load drops further.

Step-down Mode

In case that the targeted V_{out} is lower than $V_{in}+0.3V$, the ZCC2007 operates in a step-down mode with a lower peak current limit than that in step-up (boost) mode. In this step-down mode, the operation is similar to that in the PWM mode except that the gate of internal P-channel MOSFET is tied to VIN.

Current Limit

To avoid an accidental large peak current, an internal cycle-by-cycle current limit operation is adopted. The internally sensed inductor current is converted to a voltage and compared to the peak current limit. The internal N-channel MOSFET switch is turned off immediately as soon as the inductor current reaches the limit. If the load current is further increased and the





output is pulled below the input voltage, the ZCC2007 enters into short circuit protection (SCP) mode.

Short Circuit Protection

Once short circuit protection (SCP) is triggered, the ZCC2007 stops switching immediately and restarts after about 1ms as a new power-on cycle. The device continues this hiccup steady state until the overload condition is removed.

Output Disconnect

When the device is shut down, the ZCC2007 disconnects VOUT from VIN by eliminating body diode conduction of the internal P-channel MOSFET switch. This prevents either VOUT or VIN being discharged by each other when the ZCC2007 is disabled.

Output Over-Voltage Protection

The ZCC2007 provides output over-voltage protection. If the output voltage is detected above the over voltage protection (OVP) threshold, the device stops switching and both of the N-channel and P-channel MOSFET switches turn off. When the output voltage drops below the OVP voltage, the device resumes switching automatically. This function secures the circuits connected to the output from excessive overvoltage.

Low Battery Detector

The ZCC2007 integrates a low-battery detector to monitor the input battery voltage and generate an error flag when that voltage drops

below a user-set threshold voltage. The function is active only when the device is enabled. When the device is disabled, the LBO pin is high-impedance. The switching threshold is 500 mV at LBI. During normal operation, LBO stays at high impedance because the voltage at LBI is above the threshold. It becomes actively low when the voltage at LBI goes below 500 mV.

The battery voltage, at which the detection circuit switches, can be programmed with a resistive divider connected to the LBI pin. The resistive divider scales down the battery voltage to a voltage level of 500 mV, which is then compared to the LBI threshold voltage. The LBI pin has a built-in hysteresis of 10 mV. See the application section for more details about the programming of the LBI threshold. If the low-battery detection circuit is not used, the LBI pin should be connected to GND (or to VBAT) and the LBO pin can be left unconnected. Do not let the LBI pin float.

Thermal Shutdown

The ZCC2007 has a built-in temperature monitor. If the chip temperature exceeds thermal shutdown threshold, the device goes into the thermal shutdown and switching is stopped. If the temperature drops below the thermal shutdown falling threshold, the converter resumes the normal operation.



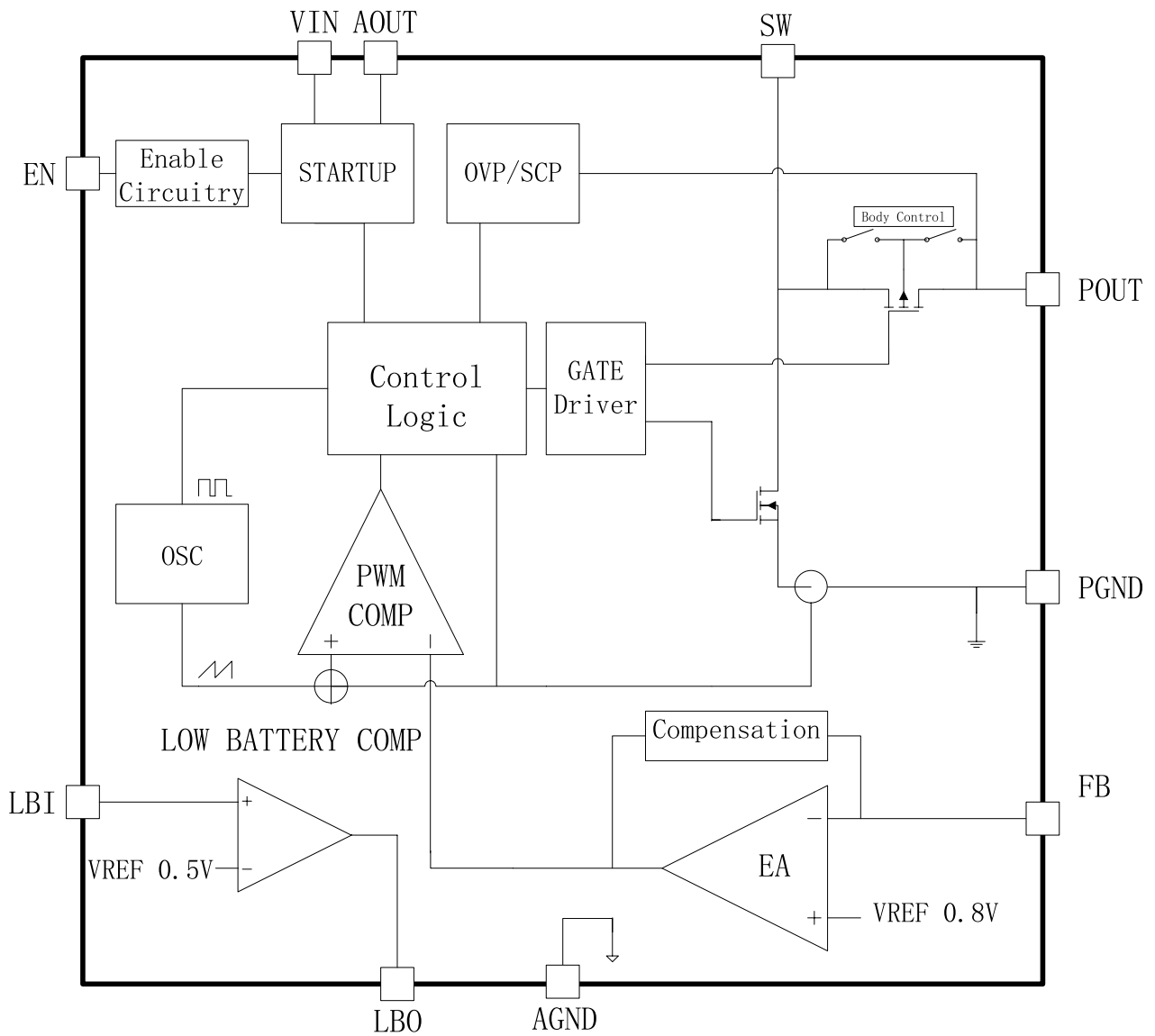

Figure 1: Functional Block Diagram





Application Information

Components referred below apply to the “Typical Application” circuit

Selecting the Input Capacitor

An input capacitor is required to supply the AC ripple current to the inductor, while limiting noise at the input source. A low ESR capacitor is required to keep the noise at the IC to a minimum. Ceramic capacitors are preferred, but tantalum or low-ESR electrolytic capacitors may also suffice.

For most applications, a minimum 10 uF input ceramic capacitor is recommended. Large values may be used to reduce input current ripples without limitations. Since the input capacitor absorbs the input switching current, it requires an adequate ripple current rating. Using a capacitor with a RMS current rating larger than the inductor ripple current is recommended (see “Selecting the Inductor” to determine the inductor ripple current).

To insure stable operation place the input capacitor as close to the IC as possible. Alternately a smaller high quality ceramic 0.1μF capacitor may be placed closer to the IC with the larger capacitor placed further away. If using this technique, it is recommended that the larger capacitor be a tantalum or electrolytic type. All ceramic capacitors should be placed close to the IC.

Selecting the Output Capacitor

The output capacitor is required to maintain the DC output voltage. Low ESR capacitors are preferred to keep the output voltage ripple to a minimum. The characteristic of the output capacitor also affects the stability of the regulation control system. Ceramic, tantalum, or low ESR electrolytic capacitors are recommended. In the case of ceramic capacitors, the impedance of the capacitor at the switching frequency is dominated by the capacitance, and so the output voltage ripple is mostly independent of the ESR.

In the case of tantalum or low-ESR electrolytic capacitors, the ESR dominates the impedance at the switching frequency.

Choose an output capacitor to satisfy the output ripple and load transient requirements of the design. A 4.7μF – 22μF ceramic capacitor is suitable for most applications.

Selecting the Inductor

The inductor is required to force the higher output voltage while being driven by the input voltage. A larger value inductor results in less ripple current that results in lower peak inductor current, reducing stress on the internal N-Channel switch. However, the larger value inductor has a larger physical size, higher series resistance, and/or lower saturations current.

A good rule of thumb is to allow the peak-to-peak ripple current to be approximately 30-50% of the maximum input current. Make sure that the peak inductor current is below 75% of the current limit at the operating duty cycle to prevent loss of regulation due to the current limit. Also make sure that the inductor does not saturate under the worst-case load transient and startup conditions. Calculate the required inductance value by the equation:

$$L = \frac{V_{IN} \times (V_{OUT} - V_{IN})}{V_{OUT} \times F_{SW} \times \Delta I}$$
$$I_{IN(max)} = \frac{V_{OUT} \times I_{LOAD(MAX)}}{V_{IN} \times \eta}$$

Where :

$I_{LOAD(max)}$ is the maximum load current

ΔI is the peak-to-peak inductor ripple current

$\Delta I = (30\% - 50\%) \times I_{LOAD(MAX)}$

η is efficiency.

Setting the Output Voltage

This is the actual output voltage. It is fed back through two sense resistors in series. The feedback voltage is 0.8V typical. The equation to the output voltage is:





$$V_{OUT} = V_{REF} \times \left(1 + \frac{R4}{R5}\right)$$

Where:

R4 is the top feedback resistor

R5 is the bottom feedback resistor

V_{REF} is the reference voltage (0.8V typical)

Choose the feedback resistors to be in the 10k or higher range for good efficiency..

PCB Layout Considerations

High frequency switching regulators require very careful layout for stable operation and low noise. All components must be placed as close to the IC as possible. Keep the path between L1 and C_{OUT} extremely short for minimal noise and ringing. C_{IN} must be placed close to the INCL pin for best decoupling. All feedback components must be kept close to the FB pin to prevent noise injection on the FB pin trace. The ground return of C_{IN} and C_{OUT} should be tied close to the GND pin. See the ZCC2007 demo board layout for reference.



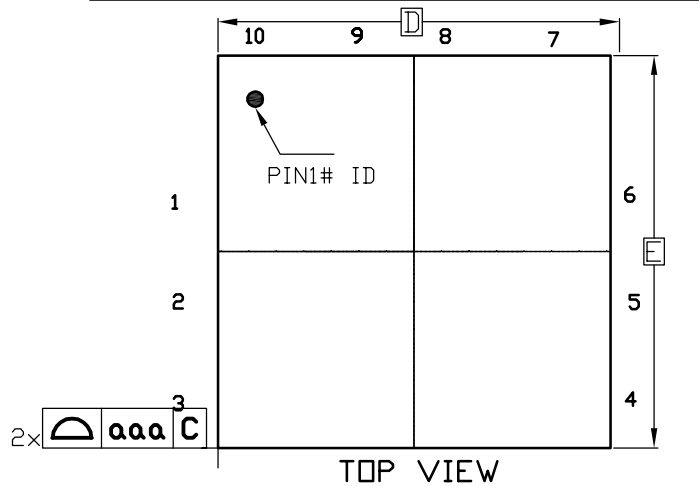

DIM SYMBOL	MIN.	NOM.	MAX.
A	0.50	0.55	0.60
A1	0	0.02	0.05
A3	-	0.152 REF	-
b1	0.15	0.20	0.25
D	2.00BSC		
E	2.00BSC		
e	0.50BSC		
L1	0.30	0.35	0.40
L2	1.25	1.30	1.35
aaa	0.15		
bbb	0.10		
ccc	0.10		
ddd	0.05		
eee	0.08		
fff	0.10		

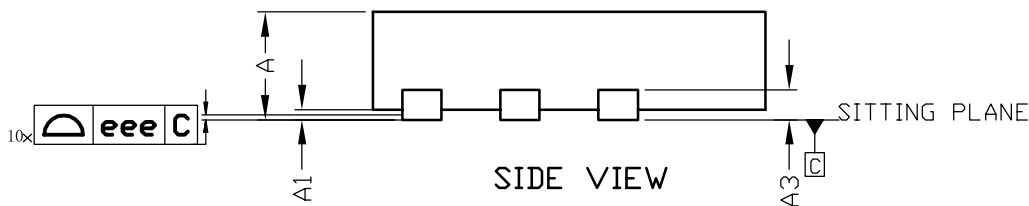
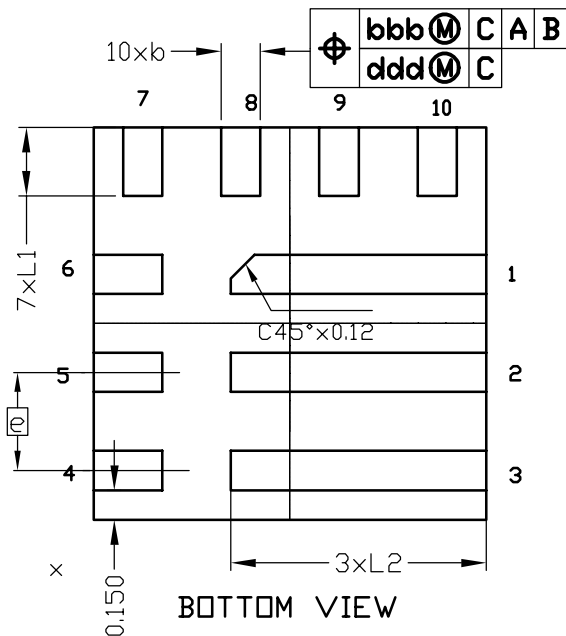

NOTES:

1. DIMENSIONING AND TOLERANCING CONFIRM TO ASME Y14.5M-1994
2. ALL DIMENSIONS ARE IN MILLIMETERS, ANGLES ARE IN DEGREE.
3. UNILATERAL COPLANARITY ZONE APPLIES TO THE EXPOSED HEAT SINK SLUG AS WELL AS THE TERMINALS.
4. DIMENSION b APPLIES TO METALLIZED TERMINAL AND IS MEASURED BETWEEN 0.150mm TO 0.30mm FROM THE TERMINAL TIP. DIMENSION b SHOULD NOT BE MEASURED IN RADIUS AREA.
5. ALL SPEC TAKE JEDEC MO-220 FOR REFERENCE.